

WELCH Vacuum Pumps & Systems

APPLIED VACUUM TECHNOLOGY



About Us

OUR PURPOSE: LEAN ON US TO HELP YOU MAKE LIFE BETTER.

WELCH Vacuum is a global business unit of Ingersoll Rand Medical Division; providing value-added Laboratory and Life Science application vacuum pumps. We proudly offer environmentally responsible Welch vacuum products for use by the scientific community and for innovative vacuum system integration in light industrial applications. Welch products are manufactured in Ilmenau, Germany – the heart of a region renowned for technical innovation – and at our Sheboygan (USA). We bring a passion for precision to the manufacture of every Welch pump, system, and component. With the latest in CAD design, CNC tooling stations, and advanced LEAN manufacturing practices, Welch stands at the forefront of progressive vacuum design and high quality vacuum product manufacturing.



MARKET SEGMENTS



■ CHEMISTRY

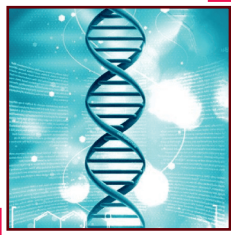

■ LIFE SCIENCE



■ INDUSTRIAL



■ PHARMACEUTICAL



■ FOOD & BEVERAGE

WELCH INDIA



Sales and Technical Support

We look forward to working with you to make your vacuum requirement perfectly matched to your application. Matched to your need. For sales and technical support, please contact our team in India.



Service Support













Our local Indian office is fully equipped with spare parts, tools and well qualified & factory trained service engineers to support our customers on post sales needs. When you need after-sales support, service or repair please refer our contact details or visit us at www.welchvacuum.com

Gardner Denver Engineered Products India Pvt. Ltd.
Block No. 878, Opposite : Gallops Industrial Park,
Sarkhej-Bavla Road, Rajoda-Bavla,
Ahmedabad - 382220, Gujarat

E : welch.in@gardnerdenver.com
M : +91 8238877700
T : 02714-619300



Product-Technology Overview:

	Pumping Technology	Ultimate Pressure	Free air displacement range	Recommended Applications	Recommended Products	
	Dry, oil-free PTFE Diaphragm Pumps	Up to 1 mbar	Up to 50 m ³ /h	Rotary evaporator, Distillation, Concentrator, Aspiration, Vacuum Ovens, Filtration, and many more	MP, MPC 105T/ 101Z/ 301Z/ 201 T/ 601T	
	Laboratory Vacuum Systems (LVS)	Up to <2 mbar	Up to 50 m ³ /h	Rotary evaporator, Distillation, Concentrator, Aspiration, Vacuum Ovens, Filtration, and many more	LVS105T10ef/ LVS210Tef/ LVS610Tef	
	Dry, oil-free Chemstar Dry vacuum pump	Up to 0.07 mbar	9 m ³ /h 18 m ³ /h	Freeze Dryer, Vacuum oven, Distillation,	2070, 2080	
	Dry, oil-free WOB-L® Piston Pumps	Up to 6.7 mbar	Up to 10 m ³ /h	Aqueous Vacuum / Pressure Filtration, Vacuum Oven, Air / Gas Sampling, Automation, Desiccation, Vacuum Chamber	2522, 2534, 2546, 2561, 2562, 2567, 2582	
	Oil-Sealed Rotary Vane Pumps (Direct drive)	Up to 10 ⁻⁴ mbar	Up to 60 m ³ /h	Freeze Dryer, Glove Boxes, Vacuum Concentrator, Vacuum Manifold / Schlenk Line, Backing Pump for High Vacuum Systems, Industrial Vacuum Process	CRVpro2 CRVpro4/6/8 CRVpro16/24/30 CRVpro48/65 Two Stage Rotary Vane vacuum pump	
	Oil-Sealed Rotary Vane Pumps (Belt drive)	Up to 10 ⁻⁴ mbar	Up to 39 m ³ /h	Freeze Dryer, Glove Boxes, Vacuum Concentrator, Vacuum Manifold / Schlenk Line, Backing Pump for High Vacuum Systems, Industrial Vacuum Process	ChemStar, DuoSeal Belt drive pump 1400, 1400N, 1405, 1402, 1402N, 1376, 1376N, 1397	

Accessories:



Vacuum Gauges

Up to 10⁻³ mbar

Vacuum Gauge & Controllers

1100 - 1 mbar



Rotary Evaporator / Distillation / Reactor

-are widely used in chemical laboratories as a way of evaporating solvents from a sample. A rotary evaporator needs to be partnered with a source of vacuum, with the vapour pressure of the solvent and the water bath temperature determining the vacuum level required.

A range of flask sizes can be used with a rotary evaporator and the size (flow rate) of the vacuum pump should be chosen based on the flask volume being used.

Application Note - Vacuum Pump

Ensure the correct vacuum level and flow rate for your pump based on the solvents being and flask size (system volume) being used. Use our model selector for guidance. Use a vacuum regulator to stop your sample from foaming and bumping

Product Selection

Welch produce a wide range of vacuum pumps and vacuum pump systems for use with rotary evaporators. With ultimate vacuum levels from 75 mbar to 1.5 mbar, flow rates up to 138 L/min and a variety of vacuum control options; there's a pump for all applications. Pumps can be regulated for better control. Regulation is available as manual and digital controller options. Some products come with vacuum regulators as standard.

» **MPC** range chemical duty PTFE diaphragm pumps for an economical option. Available in a wide range of sizes and accessories available for vacuum regulation

» **LVS** systems, built on the MPC chemical duty PTFE diaphragm pump but with added glassware and options for built in regulation - manual or digital controller.

Boiling temperature @ Atmospheric Pressure =>	80°C		110°C		160°C		> 195°C	
Example Solvents =>	Methylene chloride Acetone Chloroform Ethanol		Trichloroethylene n-Propyl alcohol Heptane Water Toluene Acetic Acid		1,1,2,2, Tetrachloroethane DMF Pentachloroethane		DMSO Polymers	
RotoVap Flask Volume ↓	Pump Models	System Models	Pump Models	System Models	Pump Models	System Models	Pump Models	System Models
1 L	↑	↑	↑	↑	↑	↑	↑	↑
2 L	↑	↑	MPC 101 Z/ DryfastEco	LVS 101 Z/ DryfastEco	MPC105T/ 2032	LVS 105 T-10 ef / 2027	↑	↑
10 L	↑	LVS 101 Z/ DryfastEco	↑	↑	MPC201T/ 2042	LVS 210 T ef / 2027	CRVpro2	1400N
20 L	MPC 110 E/ DryfastEco	LVS 301 Z/ DryfastEco	MPC 301 Z/ MPC 302 Z	LVS 301 Z/ LVS 310 Z	MPC 601 T	LVS 610 T ef	CRVpro4	1402N

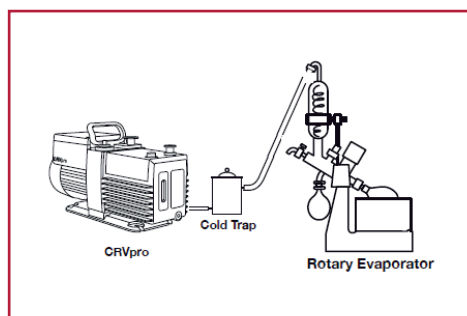
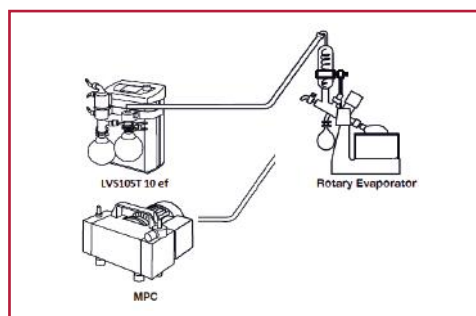

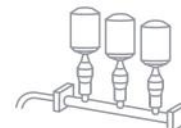

Filtration / SPE

Vacuum and pressure filtration is widely used for sample preparation in chemistry, life science, environmental analysis and pharmaceutical QC.

Application Note - Vacuum Pump

Filtration rates are greatly enhanced by creating a differential pressure across the filter unit by applying either vacuum or pressure. The ultimate differential pressure requirements are generally low. When filtering at 100 mbar, 90% of atmospheric pressure is available to assist the filtration. Improving the vacuum level to 50 mbar (95% vacuum) has little appreciable effect on the differential pressure.

Solid phase extraction (SPE) is a sample preparation technique which is growing in popularity. SPE gives better yields than traditional liquid to liquid methods and the wide range of available stationary phase forms allow for rapid processing and automation

Product Selection

Diaphragm or WOB-L piston pumps are generally used for filtration applications as excessive vacuum (e. g. from a rotary vane pump) causes boiling of the liquid being filtered, which is undesirable. For most filtration applications a modest vacuum of 75 to 150 mbar absolute, or a positive pressure of 2 to 6 bar is required, with free air displacement of 10 to 60 L/min depending on the filter size, leak rate, condition of the filter cake and whether a filtration manifold is being used to operate multiple filters simultaneously.

- » For filtration of aqueous solutions a WOB-L piston pump or standard duty diaphragm pump can be used.
- » For filtration of acidic and basic solutions or organic solvents use a chemical duty MPC diaphragm pump.
- » Pumps with regulator can be used when the filtration rate needs to be controlled or to stop evaporation of particularly volatile liquids

Filtration Solvent / Media	Chemical Example	Number of Filters	Model
Aqueous Vapors	Suspended solids sample Food slurry analysis	1-2	WOB-L 2522
		1-4	WOB-L 2534
		1-6	WOB-L 2546
		6 funnel manifold	WOB-L 2567
Mild Chemical Vapors	Weak acid / base Solutions	1	MPC 090 E
	Field environmental Samples	1	MPC 090 E with auto adapter
Low-volume Organic Vapors	Alcohol Solutions Solid Phase Extractios	1	2019C-02 / MPC 090 E
Strong Chemical Vapors	Chlorinated Solvents	1-2	MPC 301 E
	Strong acid / base Solutions	1-6	MPC 601 E
	Ketones	6 funnel manifold	MPC 602 E

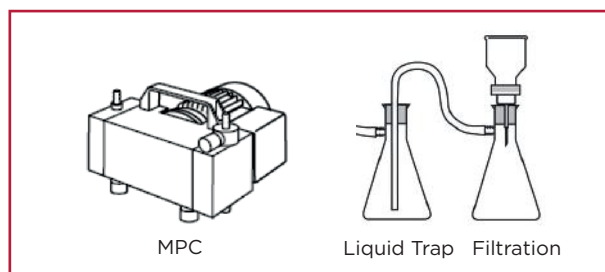
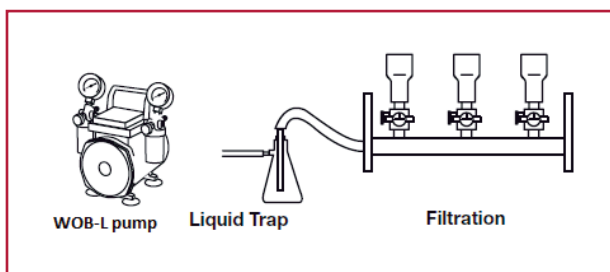



Freeze Drying / Lyophilizer

Freeze drying, or lyophilisation, is the process of freezing a material and then sublimating any frozen liquid from a solid directly to a gas. Freeze drying is commonly used as a method of preservation in food and pharmaceutical industries. It allows products to be easily stored and transported without having to be constantly refrigerated

Application Note - Vacuum Pump

Ensure that your vacuum pump is sized correctly for your freeze dryer. If the flow rate of the pump is too high then the vapour is pulled through the condenser too quickly which reduces the condensing efficiency. Clean the freeze dryer's condenser after each run to prevent sublimation of frozen chemicals into the vacuum pump.

Product Selection

For freeze drying (lyophilisation) applications a high vacuum levels is required, typically between 10^{-1} mbar and 10^{-3} mbar. Oil-sealed rotary vane pumps are most popular for freeze drying application.

Freeze Dryer Size (Collector Volume) ↓	Pump Model =>	CRVpro4	CRVpro6	CRVpro8	CRVpro16	1402N-50	1376N-50
up to 2 Ltr.		X					
up to 4.5 Ltr.			X			X	
up to 6 Ltr.				X		X	
up to 8 Ltr.				X		X	
up to 12 Ltr.				X		X	
up to 25 Ltr.					X		X

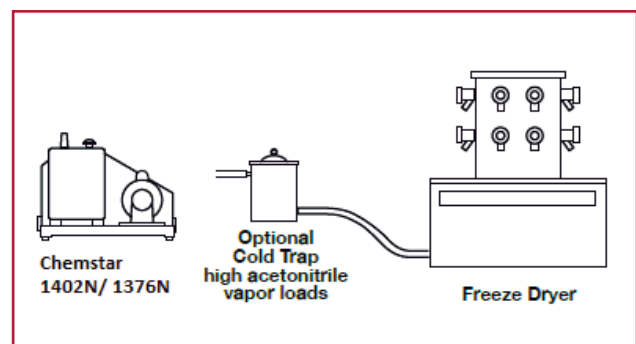
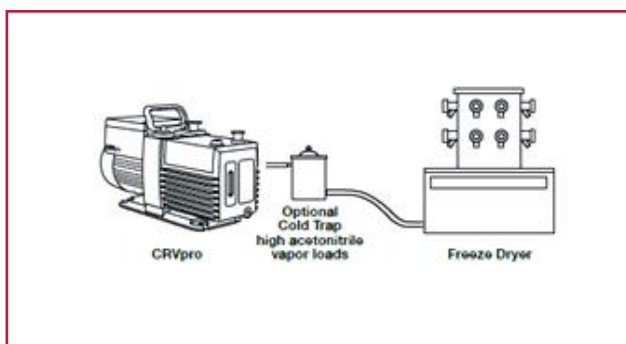

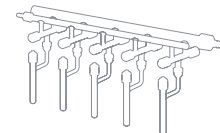

Schlenkline / Vacuum Manifold

Schlenk line (also known as vacuum manifolds) is a tubular glass apparatus used to perform air-free benchtop chemical manipulations. Air-free work is required when reagents or products are sensitive to oxidation. A Schlenk line, centrally consists of a duplex of glass tubes connected side-by-side, which together is called a “manifold.” The manifold is connected to a vacuum pump and a source of inert gas (N₂ or Ar). A Schlenk line is most safely operated within a working hood

Application Note - Vacuum Pump

It is generally not necessary to have a pump with a high flow rate for Schlenk Line applications. The flow rate of the application is restricted by the size of the manifold and stopcock. Using a pump which is too large can cause vapours to flow through the cold trap too quickly and not have time to condense. This contaminates the pump and will shorten pump life.

Product Selection

The traditional pump for Schlenk line applications is an oil sealed rotary vane pump due to their deep vacuum performance. A cold trap should be used to trap solvents before they enter the pump. Chemstar Belt Drive pumps & CRVpro range pumps are also very popular due to their high contamination tolerance capability. New ChemStarDry is a dry (oil-free) chemical resistant alternative.

System volume	Pump Model		
Up to 10 Liter	CRVpro2	ChemStar 1400N	ChemStarDry (2070C-02)
10 to 20 Liter	CRVpro4	ChemStar 1402N	ChemStarDry (2070C-02)

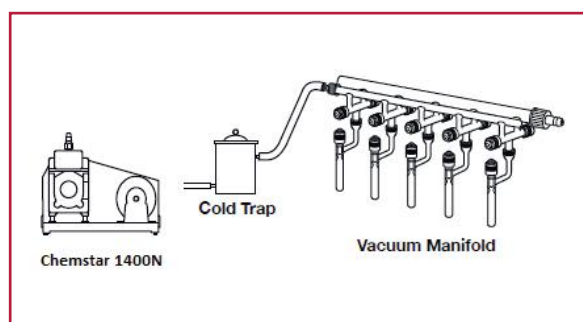
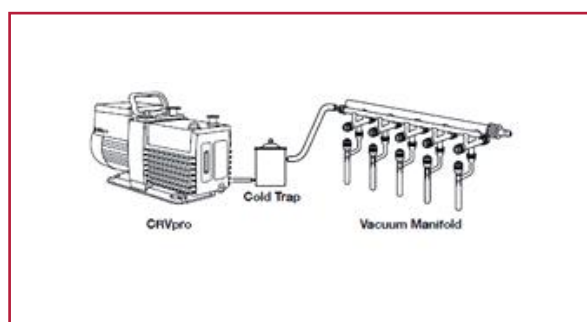

Dry ice / LN₂ Cold Trap:

When chemical vapors or large quantities of condensable vapors are evolved from vacuum processing, a cold trap may be used in the connecting line to the pump. Commonly used refrigerants are liquid nitrogen or dry ice/acetone slurry. The refrigerant to be used depends upon the freezing point of the chemical vapors.



1420H-14



Vacuum Oven

Vacuum ovens are commonly used for drying samples where one wants to dry sample at lowest possible temperature and where extremely low residual moisture levels are demanded, to avoid deterioration of the sample. Beyond sample drying, vacuum ovens are used for applications such as curing epoxies, baking-out, degassing liquids, moisture determination, aging tests, and heat treating. Vacuum pump selection depends on the oven volume, the chemistry of the vapors removed from oven, vacuum level needed for process, and the mass of those vapors removed.

Application Note - Vacuum Pump

Depending on the solvents used and the temperature limitations of the samples and chamber, a medium to high ultimate vacuum is generally required from the pump. The potentially large quantities of vapour generated from the chamber also mean that the pump should handle vapours well; these may be aqueous, basic or acidic.

- » WOB-L Piston pumps for aqueous vapors
- » PTFE diaphragm pumps are most suitable for chemical vapors.
- » High flow rates may also be needed where vapour volumes are large. Some vacuum ovens require sample drying, bakeout, curing, etc. require ultimate vacuum pressure 10^{-1} to 10^{-3} mbar range. In these situations, CRVpro range vacuum pumps offer best results.

NOTE: First start vacuum pump, when ultimate vacuum stabilizes, then start heating in vacuum oven.

Product Selection

System Volume	Pump Model		
	Aqueous Vapours	Chemical Vapours	Two Stage Rotary Vane Pump
Oven Volume ↓			
20 Liter	2561C-50	MPC 301 Z / DryfastEco	CRVpro4
50 Liter	2561C-50	MPC 302 Z	CRVpro4
120 Liter	2581C-50	MPC 601 T	CRVpro6
250 Liter	2581C-50	Chemstar Dry (2070C-02)	CRVpro8

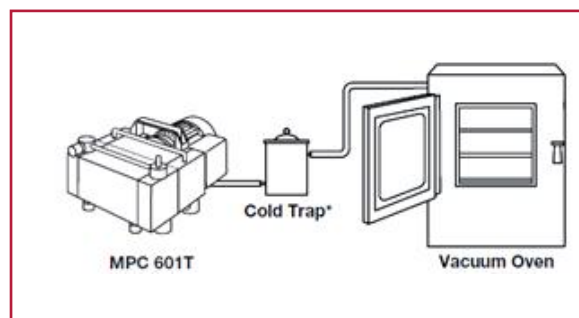
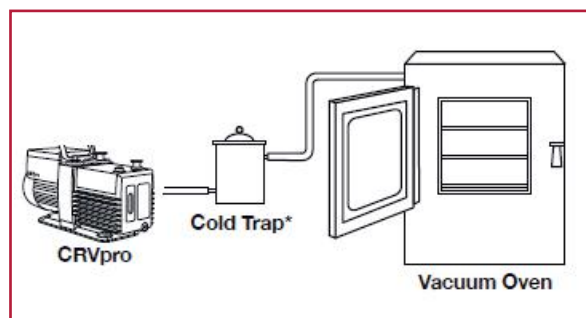

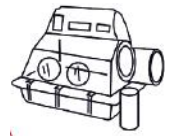

Glove Box

Glove boxes are used to house a controlled environment either for isolation of sensitive substances or to protect users from hazardous substances. A vacuum pump is used to remove ambient air from the glove box and then it can be backfilled with an inert gas, such as Argon. This process can be repeated to achieve a lower oxygen concentration.

Standard glove boxes are generally made of acrylic and polycarbonate material and transfer chambers are not normally evacuated much below 20 mbar due to plastic material limitations.

» Oil free WOB-L piston pumps are best suited for vacuum down to 5 mbar ; and for aqueous vapours.

High end glove boxes capable of deeper vacuum normally are constructed of stainless steel & heavy glass plates. These can generally be evacuated <0.01 mbar.

» Two stage rotary vane pumps used when a deep vacuum is required. With a high pumping speed these pumps are suitable for larger glove boxes also. An anti-suck back valve ensures that there is no back flow of oil into the glove box.

Acrylic Glove Boxes (Aqueous Vapor)	Metal Glove Boxes (Chemical Vapor)	
WOB-L 2581C-50	CRVpro 8	DuoSeal 1402

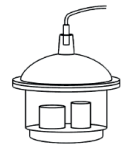

Desiccation

Vacuum desiccators are used for the removal of moisture in a sample, maintaining a dust and moisture-free environment, vacuum testing, defoaming and storing samples under various atmospheres.

» Use WOB-L piston pumps for standard duty aqueous applications, with a high pumping speed for quick evacuation of your desiccator. These pumps come with a vacuum regulator and dial vacuum gauge as standard for controlled evacuation and vacuum level monitoring.

» Use chemical duty MPC diaphragm pumps when solvents are being used. These rugged diaphragm pumps use PTFE and other chemical duty materials for protection against damage from solvents. Use the optional DBR regulator with dial gauge if vacuum regulation is required.

	Desiccator Type	Application	Pump Model
Aqueous vapours	Small benchtop	Process	WOB-L 2534
		Storage	WOB-L 2562
	Small cabinet (<25 litres)	Process	WOB-L 2534
		Storage	WOB-L 2562
	Large cabinet (>25 litres)	Process	WOB-L 2562
		Storage	CRVpro 4
Chemical vapors	Small benchtop	Process	MPC 090 E
		Storage	MPC 095 Z
	Small cabinet (<25 litres)	Process	MPC 301 E
		Storage	MPC 302 Z
	Large cabinet (>25 litres)	Process	MPC 601 E
		Storage	CRVpro 4 / 2070C-02

* Inline Cold Trap needed when using CRVpro4 or 2070C-02 pump in aqueous or chemical vapor application



Concentrator | DNA Pelleting, Oligonucleotide Prep

DNA Pelleting: MPC range PTFE diaphragm vacuum pump is recommended to quickly dry the pellet. Recommended for most centrifugal concentrators including Thermo Speedvac® and Labconco Centrивap®.

Oligonucleotide Prep and biochemical/organic sample: MPC range PTFE diaphragm vacuum pump is recommended to quickly dry samples. MPC range pumps have chemical duty PTFE diaphragm to handle aggressive chemicals such as TFA, HCL, formic acid, and acetic acid.

Application	Sample Load	Refrigeration	Model
DNA Pelleting	<1 ml, up to 24 tubes	Refrigeration trap optional	DRYFAST 2044
	≥1 ml, ≥24 tubes		MPC 901 Z
Oligonucleotide Preps	2-4 ml, up to 60 tubes	-55°C Refrigeration trap high recommended	DRYFAST 2042
	≥4ml, ≥60 tubes		MPC 601 T
Biochemical/Organic Sample	<5 ml, up to 60 tubes	-55°C Refrigeration required	DRYFAST 2042
	≥5 ml, ≥60 tubes		MPC 601 T
Biochemical or large Sample	<50 ml, up to 6 tubes;	-55°C Refrigeration required	DRYFAST 2042
	≥50 ml, ≥6 tubes		MPC 601 T

Mass Spectrometer

If you are looking for a chemistry application, robust backing pump as an economical alternative for your mass spectrometer machine ; WELCH Vacuum offers 2-stage rotary vane pump – CRVpro series. The Welch CRVpro series provides a robust alternative replacement for your malfunctioning backing pump of any brand / model.

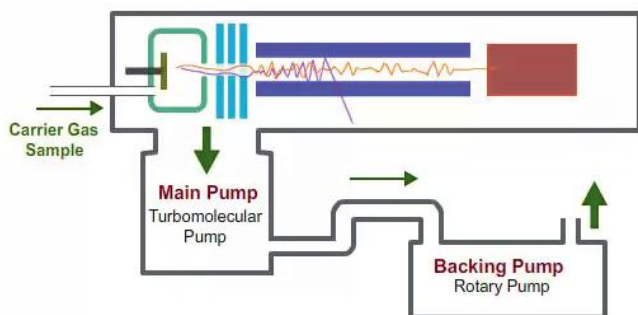

MOST COMMON VACUUM SYSTEM CONFIGURATION OF A MASS SPECTROMETER

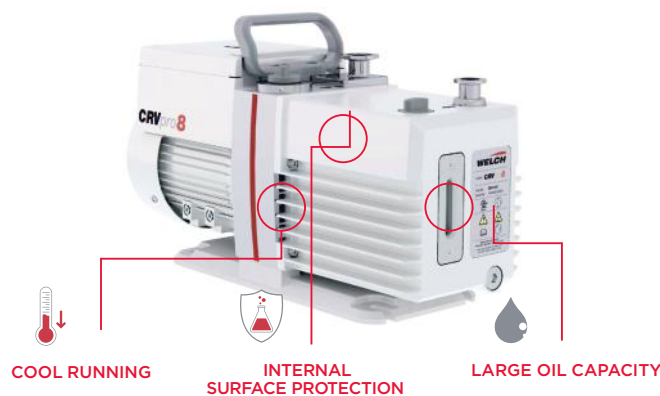

Compared to standard Rotary Vane pumps the CRVpro runs 10°C cooler due to its enhanced air flow. PTFE coating inside the oil case and a black oxide coating on the outside of the pump module ensure reduced metal corrosion rates and extend time between service intervals. The large oil chamber dilutes chemical vapors to minimize the rates of oil breakdowns and reduce chemical attacks inside.

GC-MS / SMALL TOF		ICP-MS / LOW END LC-MS			LC-MS
CRVpro 2 (2.5 m ³ /hr)	CRVpro 4 (4 m ³ /hr)	CRVpro 8 (8 m ³ /hr)	CRVpro 16 (18.3 m ³ /hr)	CRVpro 24 (26.2 m ³ /hr)	CRVpro 30 (33.1 m ³ /hr)

WELCH **MPC** range diaphragm pumps have been developed specifically to meet the harsh chemistry requirement for oil-free vacuum generation. With ultimate vacuum from 75 to 1.5 mbar and peak flow rates up to 138 Ltr/min, there is a specific model configuration to suit almost all applications. Our proven diaphragm technology offers a double benefit to the user – outstanding diaphragm life and market leading cost of ownership. The **MPC** models use PTFE and other fluorinated plastics for the wetted parts to allow aggressive solvent and acid vapours to be pumped. Ecoflex versions with variable speed motors are also available

- » Analytically pure, oil free vacuum
- » User Friendly, Lightweight, rugged design, Minimal vibration
- » Designed for permanent operation(365x24)
- » Maintenance-free drive system and proven long diaphragm life
- » Significantly improve flow and vacuum performance in critical range
- » Superior chemical resistance
- » CE Certification
- » ATEX Conformity: II3G IIC T3 X (internal atmosphere only)



Suitable for Application

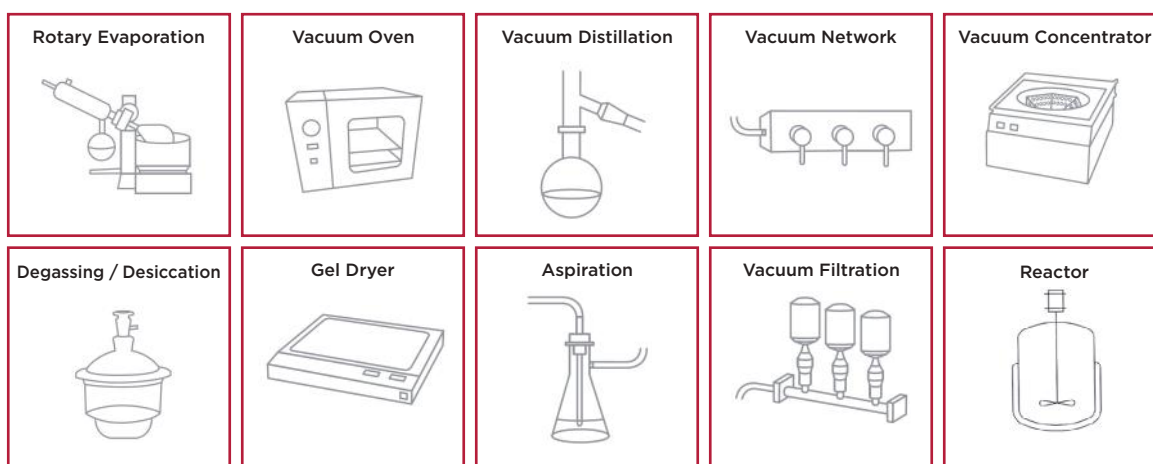

Ultimate Vacuum Selection

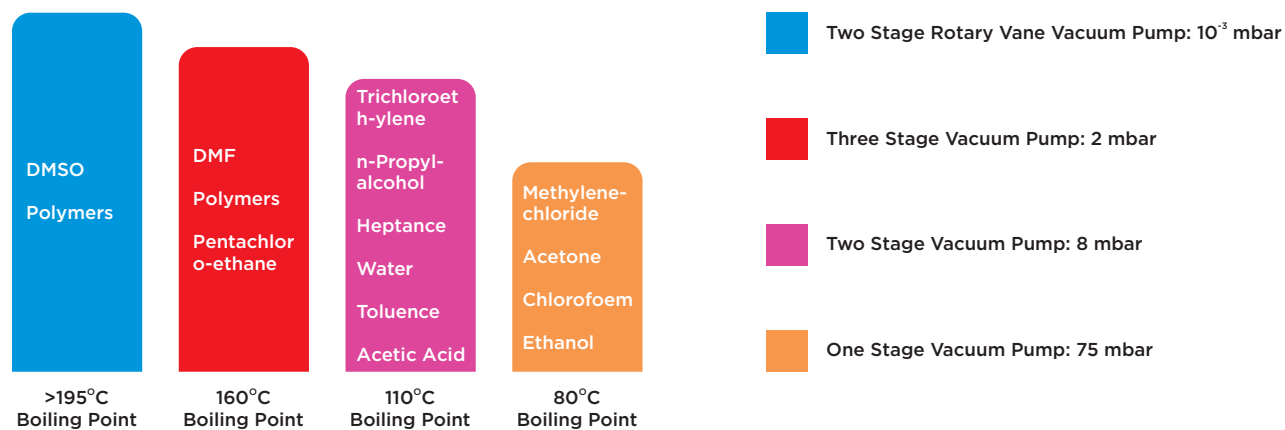

Three Stage: <2 mbar



DRYFAST ULTRA DRYFAST ULTRA

Parameter	MPC 105 T	MPC 201 T	MPC 601 T	MPC 1201 T	2032	2042
Number of heads/stages	4/3	4/3	4/3	8/3	2/2	2/2
Free Air Displacement, m ³ /h	1.2	2	4.5	8.3	0.9	1.2
Free Air Displacement, l/min	20	33	75	135	25	35
Ultimate pressure, mbar	< 2	< 2	< 2	< 2	2	2
Intake connection	Hose nozzle DN 8	Hose nozzle DN 8	DN 16 KF with optional Hose nozzle DN 8	DN 16 KF	Hose nozzle 7mm	Hose nozzle 7mm
Exhaust connection	Hose nozzle DN 8	Hose nozzle DN 8	Hose nozzle DN 8	DN 16 KF	Hose nozzle 7mm	Hose nozzle 7mm
Sound level	<45	<45	<44	<44	<45	<45
90...260VAC	412443-02	-	-	-	-	-
230V 50Hz 1ph		412543	412743	412783	2032C-02	2042C-02

Two Stage: 5 mbar



Parameter	MPC 095 Z	MPC 155 Z	MPC 302 Z
Number of heads/stages	2/2	4/2	2/2
Free Air Displacement, m ³ /h	0.9	1.4	2.6
Free Air Displacement, l/min	15	23	43
Ultimate pressure, mbar	5	5	5
Intake connection	Hose nozzle DN 8	Hose nozzle DN 8	DN 16 KF with optional Hose nozzle DN 8
Exhaust connection	Hose nozzle DN 8	Hose nozzle DN 8	Hose nozzle DN 8
Sound level	<45	<45	<44
90...260VAC	412422-02	412642	-
230V 50/60Hz	-	-	414722

Two Stage: <8 mbar



Parameter	MPC 095 Z	MPC 301 Z	MPC 901 Z	MPC 1801 Z
Number of heads/stages	2/2	2/2	4/2	8/2
Free Air Displacement, m ³ /h	1.0	2.3	6.8	12.0
Free Air Displacement, l/min	16.7	38	113	201
Ultimate pressure, mbar	< 8	< 8	< 8	< 8
Intake connection	Hose nozzle DN 8	DN 16 KF with optional Hose nozzle DN 8	DN 16 KF with optional Hose nozzle DN 8	DN 16 KF
Exhaust connection	Hose nozzle DN 8	Hose nozzle DN 8	Hose nozzle DN 8	DN 16 KF
Sound level	<44	<44	<44	<44
90...260VAC	-	-	-	-
230V 50/60Hz	412522	412722	414722	412782

Oil Free, PTFE Diaphragm Vacuum Pump

Single stage: <100 mbar



Parameter	MPC 090 E	MPC 110 E	MPC 301 E	MPC 302 E	MPC 601 E	MPC 602 E	MPC 1201 E	MPC 2401 E
Number of heads/stages	1/1	2/1	1/1	1/1	2/1	2/1	4/1	8/1
Free Air Displacement, m ³ /h	1.0	1.0	2.3	2.9	3.8	4.2	8.3	15.5
Free Air Displacement, l/min	16.7	16.7	38	48	63	70	138	258
Ultimate pressure, mbar	100	50	< 75	< 60	< 75	< 60	< 75	< 75
Intake connection	Hose nozzle DN 6	Hose nozzle DN 8	Hose nozzle DN 8	Hose nozzle DN 8	DN 16 KF with optional Hose nozzle DN 8	DN 16 KF with optional Hose nozzle DN 8	DN 16 KF with optional Hose nozzle DN 8	DN 16 KF
Exhaust connection	Hose nozzle DN 6	Hose nozzle DN 8	Hose sleeve A 10 - 8 or optional (enclosed) Exhaust silencer A 10	Hose sleeve A 10 - 8 or optional (enclosed) Exhaust silencer A 10	Hose nozzle DN 8	Hose nozzle DN 8	Hose nozzle DN 8	DN 16 KF
Sound level	<45	<45	<45	<45	<44	<44	<44	<44
90...260VAC	412021	412421-02	-	-	-	-	-	-
230V 50/60Hz	-	-	412711	414711	412721	414721	412741	412781

2-Stage, 3-Stage- PTFE Diaphragm Pump with ATEX motor



Parameter	ATEX	
	MPC 301 Zp, ATEX Kat.2	MPC 601 Tp, ATEX Kat.2
Number of heads/stages	2/2	4/3
Free Air Displacement, m ³ /h	2,3	4,5
Free Air Displacement, l/min	38	75
Ultimate pressure, mbar	< 8	< 2
Intake/Exhaust connection	Hose nozzle DN8	DN 16 KF
Sound level	<44	<44
400V 50/60Hz	4000481-04	4000511-04

*Ex Proof Conformity : II2G c IIB T4 X

Vacuum Gauge, Regulator Assembly for MPC Range Pump

CAT. No.	Accessories	For
700458	Vacuum regulator with dial gauge	MP/ MPC 301 Z, 601 E, 601 T, 901 Z, 1201 E
700458-01	Vacuum regulator with dial gauge and liquid trap	MP/ MPC 301 E
700458-02	Vacuum regulator with dial gauge	MP/ MPC 095 Z, 110 E, MPC 105 T, MPC 155 Z
700459	Vacuum regulator with dial gauge	MP/ MPC 095 Z, 110 E, MPC 105 T, MPC 155 Z
700459-01	Vacuum regulator with digital gauge & PRV	MP/ MPC 095 Z, 110 E, MPC 105 T, MPC 155 Z
700461	Vacuum regulator with dial gauge and inlet separator	MP/ MPC 095 Z, 110 E, MPC 105 T, MPC 155
700462	Exhaust condenser / solvent recovery unit	MPC 095 Z, 110 E, 105 T, 155 Z
700458-10	Vacuum regulator with dial gauge	MP/ MPC 1801 Z, 2401E, 1201T
700458-11	Vacuum regulator with digital gauge	MP/ MPC 1801 Z, 2401E, 1201T



700459-01, 700459-02



700458



700458-01, 700458-02



700459

LVS systems are specially designed for solvent distillation / evaporation applications. They comprise an oil-free chemical duty diaphragm pump (MPC) with optional control packages, liquid containment and exhaust vapour condenser. All wetted parts are made from high quality chemically resistant materials with clear plastic coated glassware to allow solvent and acid vapours to be pumped.

- » Analytically pure, oil free vacuum
- » User Friendly, Lightweight, rugged design, Minimal vibration
- » Designed for permanent operation(365x24)
- » Maintenance-free drive system and proven long diaphragm life
- » Significantly improve flow and vacuum performance in critical range
- » Superior chemical resistance
- » CE Certification
- » ATEX Conformity: II3G IIC T3 X (internal atmosphere only)



Suitable Application

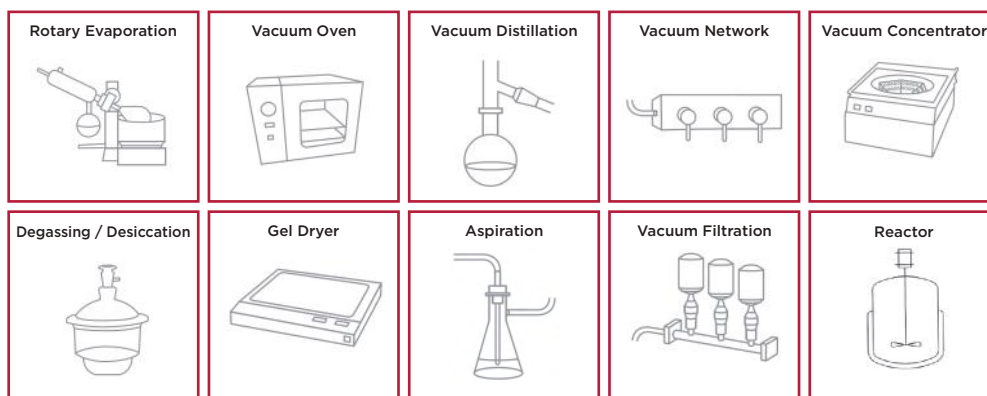

Vacuum Control Options

<p>Unregulated</p> <ul style="list-style-type: none"> » When ultimate vacuum is required at all times & also protection with inlet separator and exhaust condenser 	
<p>Manually regulated</p> <ul style="list-style-type: none"> » A fine control valve is used to regulate the vacuum by acting as a bleed valve. Options available with one or two manual regulators 	
<p>Standard digital control (using control valve)</p> <ul style="list-style-type: none"> » The standard electronic control package uses a chemically resistant solenoid valve to control the process vacuum while the pump runs continually. » The user defined vacuum and hysteresis levels are used to open and close the control valve thus maintaining vacuum at the process between the high and low control points. This is known as two point control. 	
<p>Ecoflex digital control (ef)</p> <ul style="list-style-type: none"> » Ecoflex control varies the speed of the pump constantly to maintain the user defined vacuum level regardless of changes in the process requirements. The Ecoflex method exhibits genuine single point (hysteresis-free) control and therefore a stable vacuum level. Single point control results in up to 40% increase in evaporation rates with minimal bumping or foaming of precious samples. This is particularly important in rotary evaporation application. 	

Two Stage: <8 mbar



Final pressure <8 mbar	LVS 101 Z w/gauge	LVS 110 Z	LVS 301 Z
Parameter			
FAD: m ³ /h @ 50Hz	1.0	1.0	2.3
FAD: l/min	16.7	16.7	38
Ultimate pressure, mbar	< 8	< 8	< 8
Intake/Exhaust connection	Hose nozzle DN8	Hose nozzle DN8	Hose nozzle DN8
Sound level	< 44	< 44	< 44
230V 50/60Hz	115027	115024	115047

Three Stage: <2 mbar



Final pressure <2 mbar	LVS 201 T	LVS 201 T w/gauge	LVS 210 T	LVS 601 T
Parameter				
FAD: m ³ /h @ 50Hz	1.8	1.8	1.8	4.5
FAD: l/min	33	33	33	75
Ultimate pressure, mbar	< 2	< 2	< 2	< 2
Intake/Exhaust connection	Hose nozzle DN8	Hose nozzle DN8	Hose nozzle DN8	Hose nozzle DN8
Sound level	< 44	< 44	< 44	< 44
230V 50/60Hz	115037	115037-10	115034	115057

Ecoflex Range: <8mbar



Ecoflex	LVS 310 Z ef
Parameter	
FAD: m ³ /h @ 50Hz	2.6
FAD: l/min	43
Ultimate pressure, mbar	< 8
Intake/Exhaust connection	Hose nozzle DN8
Sound level	< 44
90...260VAC	-
230V 50/60Hz	115244

Ecoflex Range: <2mbar



LVS 105 T - 10 ef	LVS 210 T ef	LVS 610 T ef	LVS 1210 T ef
1.2	2.2	4.9	9.1
20	36	81	151
< 2	< 2	< 2	< 2
Hose nozzle DN8	Hose nozzle DN8	Hose nozzle DN8	Hose nozzle DN8
< 44	< 44	< 44	< 44
114184	-	-	-
-	115234	115254	115264

Two Stage: 2 mbar



WELCH Model	w/Analog Gauge 2026	w/Digital Gauge 2027	Programmable w/Digital Gauge 2028
FAD : m ³ /hr(l/min.) @50Hz	1.7(29)	1.7(29)	1.7(29)
Ult. Vac. Pressure, torr(mbar)	2(2.7)	2(2.7)	2(2.7)
Motor Horsepower(watts)	1/5(150)	1/5(150)	1/5(150)
Intake(Exhaust) Thread NPT	3/8	3/8	3/8
Wired for 230V, 50/60Hz, 1Ph,	202603	202703	202803

With the new ChemStar Dry, you get the advantage of two combined technologies: vacuum blower and PTFE diaphragm pump. The result is an oil-free, vacuum system producing 10^{-2} mbar ultimate pressure and ready to work in your tough chemistry applications. ChemStar Dry pumps quickly down ($9\text{m}^3/\text{hr}$) to the working range for most evaporative operations (2 to 0.1 mbar) with an ultimate pressure of 10^{-2} mbar. The integrated self-cleaning function also contributes to the system's long lifetime and enables repeatable results.

Applications

ChemStar Dry is suitable for all applications where high gas flow and deep vacuum are needed.

- Schlenk Line
- Vacuum Oven
- Glove Boxes
- High vacuum distillation/ drying



> Oil-Free

- No oil back-streaming
- No oil maintenance/disposal
- Cleaner work place
- Cleaner samples
- Less maintenance



> Low vacuum mostly without cold trap

- Less maintenance
- Lower cost of ownership
- Extra bench space



> Plug and Play

- Patented software control
- Auto speed control from atm to 0.07 mbar
- Self-cleaning function
- Protection from surges



> Chemical Resistant

- Pumps corrosive vapour/gases
- PTFE and proprietary coatings

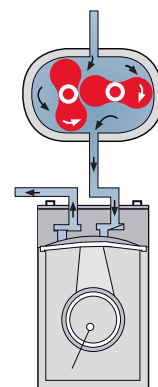

Vacuum fittings, Rubber Vacuum hose



Multi Range Vacuum Gauge
 Digital Display Shows precise Vacuum levels



Foreline Catchpot Trap.
 Catchpot trap mounts directly on inlet of pump via NW25 flange connection. Properly maintained trap prevents ingestion of liquid by pump. Liquid ingestion will cause pump to fail.

Specifications	2070C-02	2080C-02
Ultimate vacuum	7×10^{-2} mbar	7×10^{-2} mbar
Free air displacement	9 m ³ /hr	18 m ³ /hr
Inlet-/Outlet Connection	DN 25 KF	DN 25 KF
Overall Dimension (cm)	46 x 22 x 47	57 x 27 x 45

Wired for 230V, 50/60 Hz, 1 Ph

*WELCH recommends use of good cold trap & exhaust condenser protect pump & environment.

Oil Free, WOB-L® Piston Vacuum Pumps



Specification	Vacuum/Pressure Pumps						
Welch Model	2511	2534	2546	2561	2562	2567	2581
FAD: m ³ /hr (l/min.)@50	0.55(9.2)	1.7(28)	2.3(38)	3.4(57)	3.4(57)	4.9(83)	4.9(83)
Ult. Vac. Pressure, torr(mbar)	219(292)	70(93)	60(80)	5(6.7)	9(12)	60 (80)	4(5)
Max Pressure PSIG	33	50	100	----	33	100	100
Maximum Vacuum, in. Hg	21.3	27.2	27.6	29.8	29.6	27.6	29.8
Motor Horsepower(watts)	25	93	190	250	250	250	250
Tubing Needed, I.D.(mm)	5	5	5	7	7	7	10
Wired for 230V,50Hz, 1 Ph	2511C-02	2534C-02	2546C-02	2561C-50	2562C-02	2567C-02	2581C-50

WELCH Standard Duty Dry WOB-L pumps are ideal for pumping aqueous vapor. These WOB-L piston pumps have a high water vapor tolerance. Pumps come with inlet liquid trap, mounted vacuum gauge and vacuum regulator (except 2511 and 2562). Standard Duty Dry Pumps are not recommended for pumping organic, acidic and basic vapors.

Cell-Culture Aspiration System

The compact and portable Aspiration System with an integrated resistant diaphragm pump is used for the safe and precise aspiration of non-flammable chemical, biological, and medical liquids. The fluids can be removed easily and very precisely from slides, Petri dishes, cell culture containers etc., by using different pipettes or glass tips and pasteur pipettes which can be easily connected to the handvac pipettor.



Parameter	# 2511C-75
Free Air Displacement @ 50 Hz	9.2 L/min.
Ultimate pressure, mbar	292
Power	230V 50Hz 1 ph
Collection reservoir size	1.2 litre



Parameter	# 2515C-75
Free Air Displacement @ 50 Hz	28 L/min.
Ultimate pressure, mbar	93
Power	230V 50Hz 1 ph
Collection reservoir size	1.2 litre

Accessories



Foot Switch



Hand Pipette set



8 channel needle



Aspirate



Filtrate

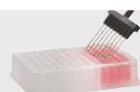

Rinse



Dispose



Discover the evolution of two-stage rotary vane vacuum pumps. Built to last. Born to perform and designed to simplify your work. Meet the robust vacuum pump series - CRVpro.

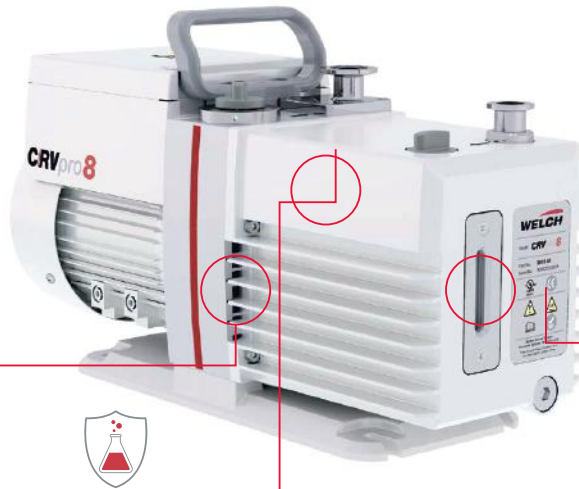

COOL RUNNING

Enhanced air flow allows the pump to run 10°C cooler than standard rotary vane pumps. The lower temperature leads to reduced chemical activity within the pump and slows down rates of oil consumption.



INTERNAL SURFACE PROTECTION

Inside surface of the oil case has a PTFE coating and the outer surface of the pumping module has a black oxide coating. Both coatings act to slow metal corrosion and, when coupled with foreline traps, extend service interval.



LARGE OIL CAPACITY

Chemical vapors that sublime from the foreline cold trap into the pump oil are more diluted due to the larger oil capacity. This minimizes the rates of oil breakdown and reduce chemical attacks within the pump.

▶
▶
▶

HIGHEST RELIABILITY
LONG PRODUCT LIFESPAN
LESS MAINTENANCE

EXTENDS SERVICE INTERVAL

Standard Features of CRVpro

» **LOW NOISE LEVEL**

Exceptionally quiet for undisturbed work.

» **FORCED OIL LUBRICATION**

Ensures moving parts are bathed in fresh oil. Equilibrates temperature, minimizes oil breakdown, and prolongs mechanical life.

» **ANTI-SUCK BACK VALVE**

Prevents oil from being sucked into application in the event of a power failure.

» **GAS BALLAST WITH INERT GAS OPTION**

Minimizes entrained chemicals in pump oil. Protects pump from condensable liquids from application such as water, acetyl nitrile, etc.

» **cUL AND CE CERTIFICATION**

Compliance with local regulations and safety directives for safety operation.

» **SIZED TO FIT YOUR APPLICATION**

Modern and compact design to fit different applications and performance requirements.

» **DUAL VOLTAGE MOTOR**

Dual voltage motors meet IP54 standard. Motors of CRVpro 2,4,6,8 are switchable from 115V to 240V for global use excluding 100V and 200V pump versions. Each pump includes power cord suitable for country use.

CRVpro | TWO STAGE ROTARY VANE VACCUM PUMP



TECHNICAL SPECIFICATION

Parameter	CRVpro 2	CRVpro 4	CRVpro 6	CRVpro 8	CRVpro 16	CRVpro 24	CRVpro 30	CRVpro 48	CRVpro 65
FAD @ 50Hz m ³ /h (L/min)	2.5 (41.7)	4 (67)	6 (100)	8 (133)	18.3 (305)	26.2 (436)	33.1 (551)	55.7 (928)	74.3 (1238)
- Without gas ballast partial mbar (Torr)	3x10 ⁻⁴ (2x10 ⁻⁴)	5x10 ⁻⁴ (4x10 ⁻⁴)			3x10 ⁻⁴ (2x10 ⁻⁴)			3x10 ⁻⁴ (2x10 ⁻⁴)	
- Without gas ballast total mbar (Torr)	3x10 ⁻³ (2x10 ⁻³)	2x10 ⁻³ (1.5x10 ⁻³)			3x10 ⁻³ (2x10 ⁻³)			3x10 ⁻³ (2x10 ⁻³)	
- With gas ballast total mbar (Torr)	9x10 ⁻² (7x10 ⁻²)	7x10 ⁻² (5x10 ⁻²)			6x10 ⁻³ (5x10 ⁻³)			6x10 ⁻³ (2x10 ⁻³)	
Connection Flange (KF)	16	16 KF			25 KF			40 KF	
Ambient temperature (°C)	10-40	10-40			10-40			10-40	
Noise level (dBA)	≤50	50 dB			55 dB			≤58	
Oil capacity (ml)	450	1150	1000	2400	2200	2100	4950	4300	
Motor speed (rpm 50/60Hz)	1450/1740	1450/1740			1450/1740			1460/1760	
Motor power (kW 50Hz)	0.27	0.37			0.7			2.2	
220-240V 50Hz, 1ph(Part #)	3022-00	3042-00	3062-00	3082-00	3162-00	3242-00	3302-00	-	-
230-240/380-420 V/50 Hz 3 phase motor, requires hard wiring (Part #)								3487T-01	3657T-01

Every pump is supplied with oil, centering rings(qty 2), clamps (qty 2).

INLET ACCESSORIES



Inlet Liquid Trap



Dryice/ LN2 Trap



Acid Neutralization Trap



Adsorption Trap



Reducer KF Flange

HOSE AND CONNECTORS



RED Rubber Hose



Clamp



Centering Ring



Metal Hose



Hose Nozzle

EXHAUST ACCESSORIES



Exhaust Oil Mist Filter with Oil Return



AKD - Oil Mist Filter



Directorr Premium Oil

CRVpro PUMP OIL

1392 : ProBoost™ : Gas Jet Vacuum Pump

Welch's ProBoost is an air cooled gas jet vacuum pump. The gas jet is formed by directing boiling silicone vapors thru a hollow cone. No internal moving parts. The pumping action commences when the vacuum pressure in the still (ie wiped film) goes below 0.2 Torr. On an empty, leak free still, ProBoost backed by a rotary vane pump lowers the vacuum pressure to **0.00002 Torr** (20x lower in pressure than a 2-stage rotary vane pump can do alone).

The benefit of the lower vacuum pressures is fractions are pulled off at lower temperatures, more precisely. Stills see improvement in feed rates/collection rates due to ProBoost's lower pressures and increased flow rates.



(ProBoost 1392C-02)

Suitable Application

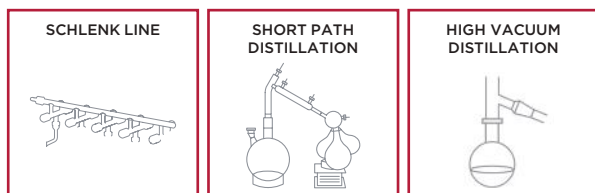

- » Increases the pumping speed below 10^{-3} torr
- » Enhances vacuum to 10^{-5} torr
- » Distill high boilers at lower temperature
- » Easy to attach to most rotary vane pumps or CHEMSTAR DRY



ProBoost connected to a CRVpro rotary vane pump configured with optional pump connection kit (cat. no. 1392K-01) and high vacuum butterfly valve (704523)

*ProBoost comes with NW50 clamp, NWS0 centering ring, NW2S clamp, NW25 centering ring, line cord, cooling fan, switch, control board and 100 ml of Welch ProBoost Silicone Oil

Model	1392C-02
Pumping speed	80 Ltr/sec for air
Ultimate vacuum	2×10^{-5} Torr
Pump dimensions LxWxH, (in)	5.5 x 5.4 x 7.5
Pump weight (kg)	2.4
Inlet Connection	NW 50
Discharge connection	NW 25

Dry ice / LN2 Cold Trap:

When chemical vapors or large quantities of condensable vapors are evolved from vacuum processing, a cold trap may be used in the connecting line to the pump. Commonly used refrigerants are liquid nitrogen or dry ice/acetone slurry. The refrigerant to be used depends upon the freezing point of the chemical vapors.



1420H-25
(Trap with KF25 ends)

Vcpro 601 Vacuum Controller

- » The Welch Model VCpro 601 vacuum controller measures and display's vacuum pressure both graphically and digitally. The vacuum pressure can be controlled from 1100-1 mbar (825 to 0.75 Torr). Controlling the pressure can be done in real-time. Full flexibility and repeatability is achieved easily via a programmable mode with pressure over time defined by the user.
- » Durable, chemically resistant sensor built into the VCpro 601 vacuum controller is a ceramic thick film hybrid. The sensor reading is gas independent and gives an absolute pressure.
- » Direct communication can be maintained between PC and controller to for logging data via RS232 or LAN. Model VCpro 601 controls vacuum pressure by opening and closing of a solenoid valve that is plumbed in-line between the vacuum pump and the system being evacuated.
- » Vcpro 601 can control vacuum pressure in your system from different types of vacuum sources.

DESCRIPTION	VCpro 601
Vacuum Pressure Control Range, mbar (Torr)	1100-1 (825-0.75)
Communication	RS 232/RJ 45 LAN
Connection to pump	DN8 hose nozzle
Connection to Vacuum Apparatus	DN8 hose nozzle
Inert Gas Port to Release Apparatus	DN4 hose nozzle
Dimensions: W x D x H mm	195 x 178 x 105
Part #115-230V 50/60Hz 1Ph with Internal Sensor	600100



Multi-range vacuum gauge VMpro 2 CHEM

- » Welch Model VMpro2 CHEM Vacuum Gauge, is a rugged, portable vacuum measurement instrument designed specifically for the demands of high vacuum reading of corrosive gases.
- » The built-in digital display gives clear readability for easy vacuum level monitoring and also shows the current measuring principle. There is a status indication light on top of the sensor.
- » Vmpro2 gauge is a combination gauge consisting of a Pirani sensor and a diaphragm capacitive sensor. Both sensors are constantly active. At low pressures, only the signal of the Pirani sensor is used for pressure measurement; at high pressures, only the signal of the diaphragm capacitive sensor. To determine the output signal in the intermediate range, both signals are used proportionally to the pressure.



The vacuum gauge VMpro 2 is intended for:

- » Measuring absolute pressures in the rough and fine vacuum range which is created by, for example: diaphragm pumps, piston pumps, rotary vane pumps and similar vacuum devices
- » Use in physical and chemical laboratories in education, R&D and industry
- » Use for vacuum monitoring in Schlenk line, freeze drying, distillation, vacuum concentration, vacuum drying and other vacuum technology applications.

DESCRIPTION	DATA
Measuring Range	1500 to 5×10^{-5} mbar
Operation temperature	+10 to +50 °C
Vacuum connection	DN 16 KF
Mounting Orientation	Any orientation
Ordering Part #	600094 : VMpro 2 Chemical resistant, DN16KF, 100-240V 50/60Hz 1ph

Accessories



Metal Vacuum Hose



Rubber Vacuum Hose



KF connectors



Accessories for KF Connectors



Particulate, In-line Filter to protect vacuum pump from fine particulate and aerosols to 0.2 microns.



Hose Connectors, fittings



High vacuum in-line valve



700556

Mini-Vacuum Network



Inlet/Exhaust Separator Jars



Acid Neutralization Trap



DRY ICE / ISOPROPANOL Cold TRAP (-79°C)



Ex-Condenser



Rotary vane vacuum pump oil



High vacuum butterfly valve



Fine vacuum 2way ball valve



Contact us:

S L Moran Ltd
Shatner Center , building 7 Givat Shaul
Jerusalem, 9546106

P.O.Box 34542, Jerusalem 9134402

Phone: 074-7029898

e-mail: office@slmoran.co.il

WhatsApp: 054-6294155

THOMAS

WELCH

TRICONTINENT

**ZINSSER
ANALYTIC**

ILS

Vacuum Pumps & Systems
www.welcvacuum.com